

OMBRA EXTERNAL AWNINGS



Installation Guide Zip Guide



Z-LOCK™ TECHNOLOGY

inspired spaces

- > 1800 007 321
- > apollopatios.com.au



SECTION A TOOLS AND ADDITIONAL ITEMS REQUIRED	3
TOOLS REQUIRED	3
ADDITIONAL ITEMS REQUIRED (NOT SUPPLIED)	3
BLIND ITEMS REQUIRED	4
SECTION B INSTALLATION	5
PART A – PREPARING INSTALLATION SPACE	5
PART B – SPRING PRE-TENSIONING	9
PART C – COVER ASSEMBLY	14
PART D – BOX INSTALLATION	15
PART E – COVER INSTALLATION	15
PART F – OPEN BRACKET INSTALLATION	16
PART G – BLIND INSTALLATION	16
PART H – ADJUSTING PRE-TURNS (SPRING OPERATED BLINDS ONLY)	19
PART I – SIDE GUIDE INSTALLATION	20
PART J – ULTRA-LOCK MOTOR SETTINGS	25
PART K – ULTRA-LOCK OPERATION (MOTOR OPERATION)	27
PART L – ADJUSTING MOTOR LIMITS	28
PART M – ULTRA-LOCK OPERATION (MANUAL OPERATION)	29
PART N – WEIGHT BAR SB07 LATCH INSTALLATION	31
PART O – INSERT BOX / COVER	32
SECTION C INSTALLATION SCENARIOS	33
PART A – MULTIPLE BLINDS INSTALLED SIDE BY SIDE ON A FACE FIX INSTALLATION	33
SECTION D TROUBLESHOOTING	36

DISCLAIMER

INTRODUCTION

This Installation manual for ZipGuide has been produced by Rollease Acmeda to supply the necessary information for the safe and correct installation of ZipGuide.

DISCLAIMER

Apollo Patios has used reasonable care in preparing the information included in this document, but makes no representations or warranties as to the completeness or accuracy of the information. Information is supplied upon the condition that the persons receiving the information will make their own determination as to its suitability for their purposes prior to use. Apollo Patios assumes no liability whatsoever for any damages incurred by you resulting from errors in or omissions from the information included herein. Apollo Patios reserves the right to make changes without further notice to any products to improve reliability, function or design.

COPYRIGHT

COPYRIGHT © CW SYSTEMS

All rights are reserved. No part of this document may be reproduced or utilised in any means, by any means, electronic or mechanical including photocopying, recordings, or by any information storage or retrieval system, without the express permission from CW Systems.

TOOLS REQUIRED

- Saw
- Drill
- Drill Bits – 2.5mm, 2.6mm, 3mm, 3.2mm & 4mm
- Screw Driver – Philips Head
- Scissors
- Measuring Tape
- Spirit Level

ADDITIONAL ITEMS REQUIRED (NOT SUPPLIED)

To install a ZipGuide, the following non-stocked items are required:

- Fixings for Box/Open Brackets/Hardware (ensure appropriate fixings are used to suit application)
- Trims to conceal packing (if required)

BLIND ITEMS REQUIRED

BOX



COVER (FULL OR FASCIA COVER)

A 40mm offcut of the Box 120 Back is recommended every 1200mm to support the Cover.

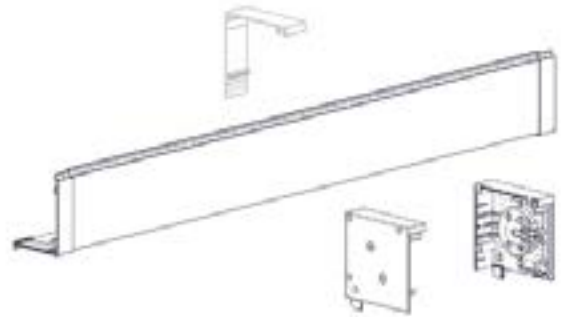

NOTE: Ensure to pre-drill holes before fixing

SIDE GUIDES

SIDE GUIDES: SIDE FIX



SIDE GUIDES: FACE FIX OPTION 1



SIDE GUIDES: FACE FIX OPTION 2



OR

OR

OPEN BRACKETS

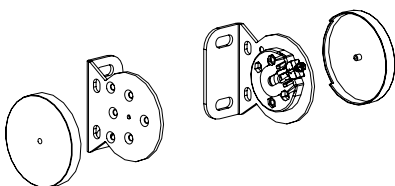

NOTE: Store Idler/Spring Adapter retaining clip until required (can be left in adaptor as shown)

BLIND



RIVETS / SCREWS - QUANTITY AS REQUIRED



PART A – PREPARING INSTALLATION

STEP 1 – CHECK FOR OBSTRUCTIONS

Check for any obstructions that may interfere in installation.

E.g. If there is an architrave at the bottom of a post that the ZipGuide is to be installed into, ensure you prepare the space for the installation.

This may mean that the installer needs to cut into the architrave to make room for the side rails.

STEP 2 – CHECK TOP OF INSTALLATION IS LEVEL

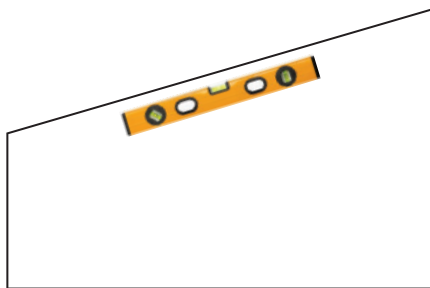

If un-even go to step 3

If level go to step 4

STEP 3 – PACK AND LEVEL TOP OF INSTALLATION TO SMALLEST DROP DIMENSION

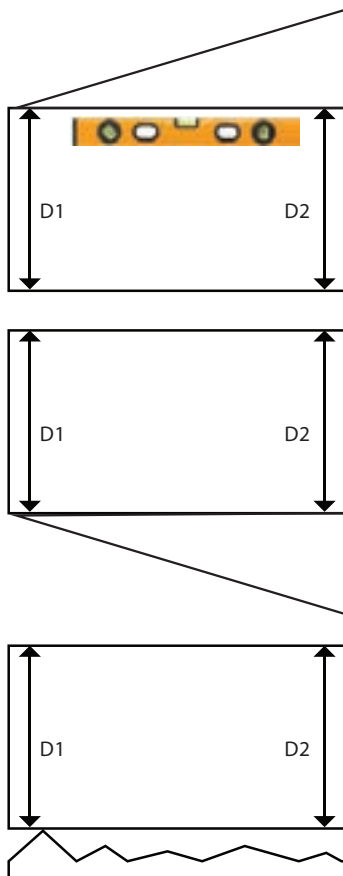

D = Drop of Blind

NOTE: In some instances, when the drop is level D1 & D2 will not be equal as there is an uneven ground.

Ensure the smallest value of D1 & D2 = Blind Drop (D specified in initial measurement)

STEP 4 – CHECK HORIZONTAL INSTALLATION DIMENSION AT TOP, CENTRE & BOTTOM

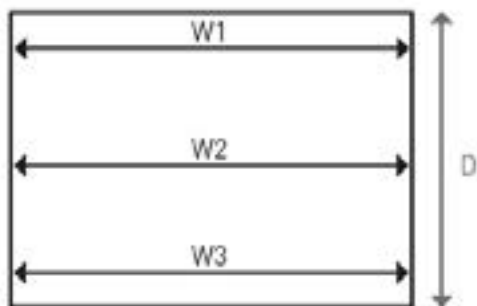

W = Width of blind

If W1, W2, & W3 are equal or within 10mm of each other, proceed to Step 5 for Side Fix applications, or Step 6 for Face Fix applications.

If W1, W2, & W3 are not equal or within 10mm of each other, review the scenarios outlined in Step 4 and determine if and where packing is required.

When using face Fix U Mounting Rail, W3 must be less than or equal to W1.

The following steps describe scenarios when using L Fixing Rail in application.

STEP 5 – PACK INSTALLATION WIDTH TO BLIND WIDTH MEASUREMENT

SCENARIO	PACKING DETAILS
<p>W3 is greater than W1 and W2</p>	<p>Determine dimension x on each side</p> <p>If X1 or X2 is less than 10, no packing necessary (however, a square space will provide greater flexibility with the rest of the installation). If x is equal to or greater than 10, packing is required. Pack out the largest dimensions (W3) to be within 10mm of the smallest dimension (W1). Ensure W1 = Blind Width (Blind width is specified in initial check and measure) Proceed to Step 6 for Side Fix applications, or Step 7 for Face Fix applications</p>
<p>W1 is greater than W2 and W3</p>	<p>Pack space so that the top is equal to or within 10mm of the smallest dimension (W3) Ensure W3 = Blind Width (Blind width is specified in initial check and measure)</p> <p>Proceed to Step 6 for Side Fix applications, or Step 7 for Face Fix applications</p>

STEP 6 – CHECK SIDES OF INSTALLATION ARE LEVEL (FOR SIDE FIX APPLICATIONS ONLY)

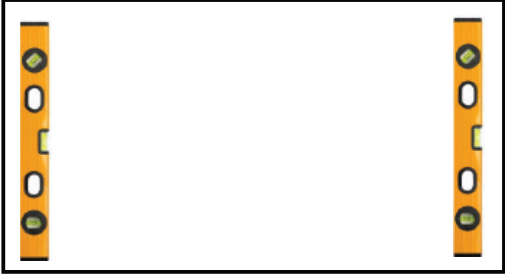
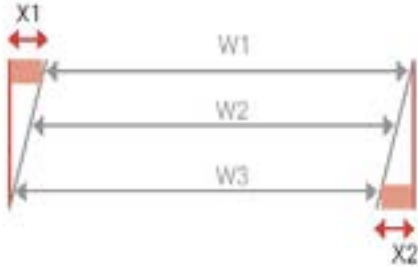
SCENARIO	PACKING DETAILS
 <p>W3 is greater than W1 and W2</p>	<p>Determine dimension x on each side</p>  <p>If X1 or X2 is less than 10, no packing necessary (however, a square space will provide greater flexibility with the rest of the installation).</p> <p>If X1 or X2 is equal to or greater than 10, packing is required. Pack out the sides so they are level or within 10mm of W1.</p> <p>Ensure the finished W1 width = Blind Width (Blind width is specified in initial check and measure)</p>

STEP 7 – CHECK AND ENSURE THE INSTALLATION SPACE IS LEVEL & SQUARE

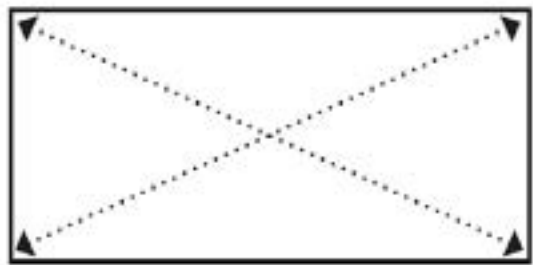

STEP 8 – IDENTIFY HIGHEST POINT ON FLOOR/GROUND

Take multiple readings to measure the highest point on floor/ground.

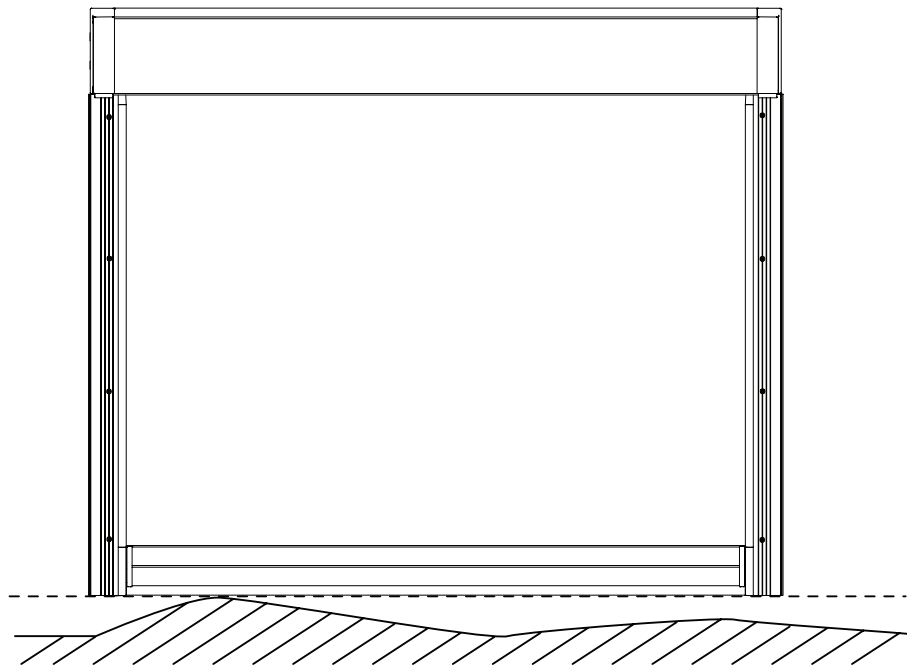
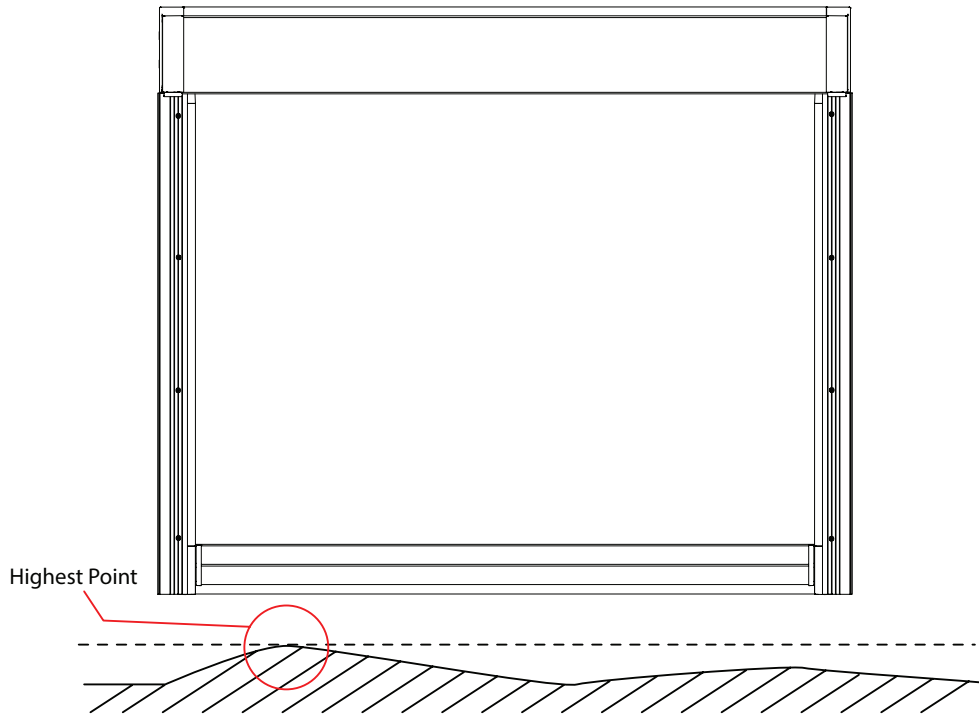

Note: Whilst installing the shade (in the next sections), ensure that the base of the side guides should not be lower than the measured highest point on floor/ground.

78mm Tube [F56 Weight Bar + 0.8kg/m Ballast]

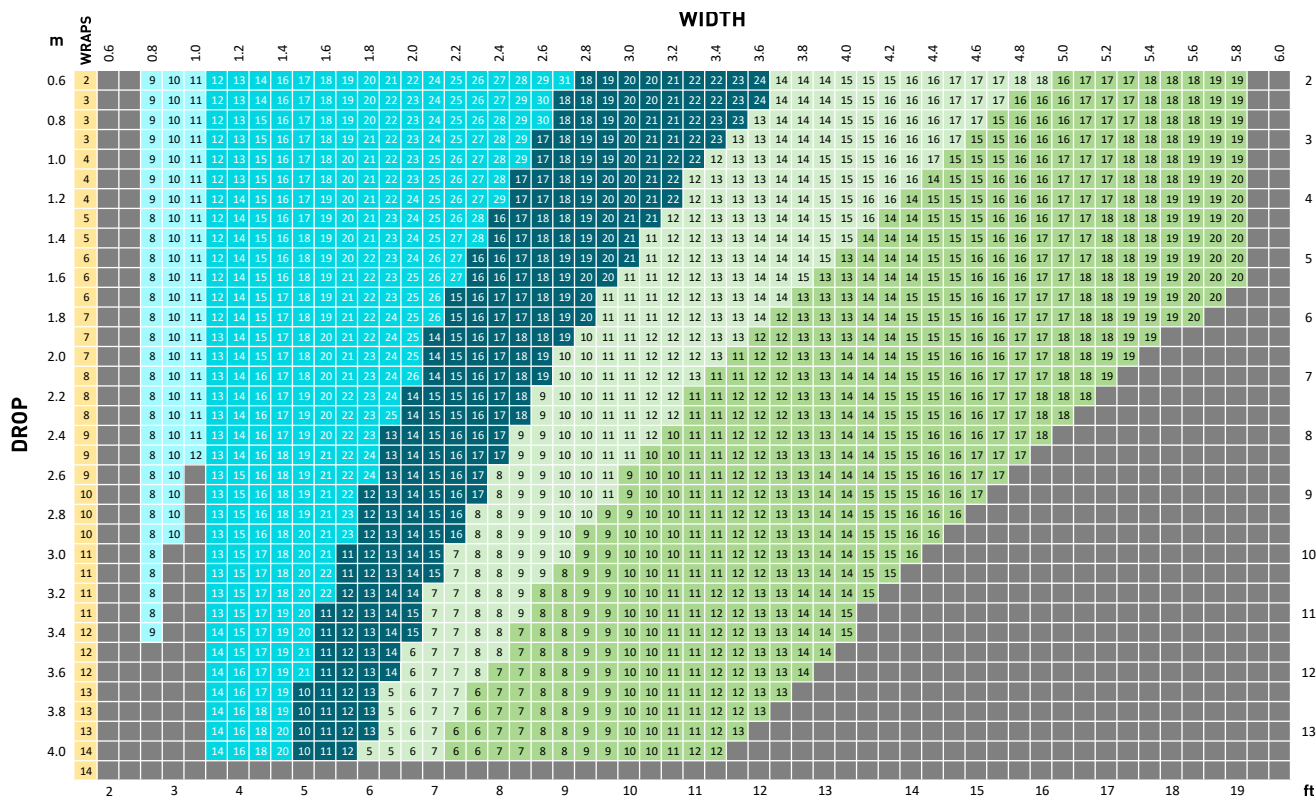

PARAMETERS

- Tube:** 78 HD Aluminium Tube (includes 78 AL STD & 78 STEEL)
- Fabric:** 573gsm (19.36oz/yd²), 0.85mm Thick
- Weight Bar:** F56 HD External Weight Bar + 0.8kg/m Ballast

LEGEND	DESCRIPTION	MAX SPRING ROTATIONS
	Outside Product Specifications	-
	Short RE01 Spring	25
	Standard RE01 Spring	38
	Heavy Duty RE01 Spring	31
	X-Heavy RE01 Spring	25
	Dual Heavy RE01 Springs	31 (Per Spring)

The above charts are indicative only and indicate the minimum number of pre-turns required. Due to variances in fabric weights, additional ballast weight and installations the optimum number of pre-turns will vary. Pre-turns can be adjusted during installation.

78mm Tube [F72 Weight Bar]

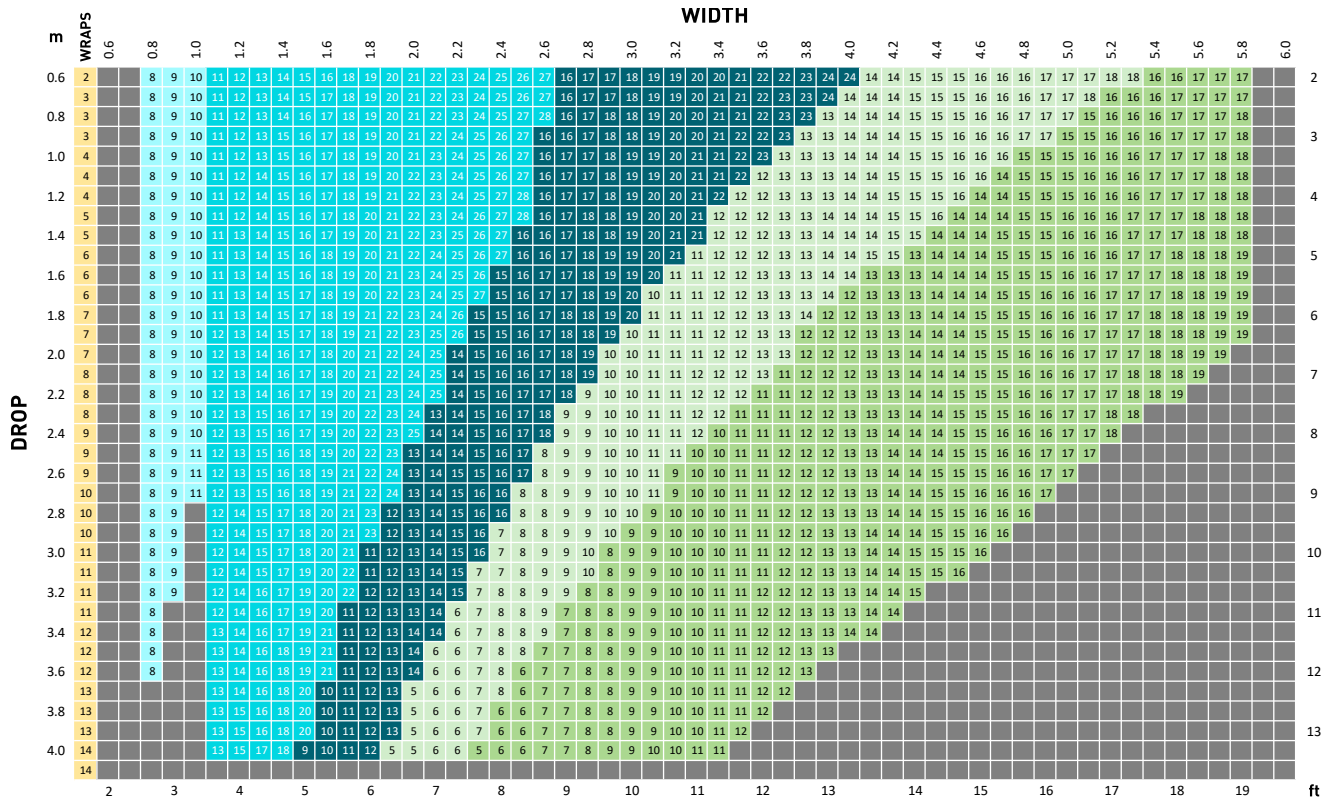

PARAMETERS

- Tube:** 78 HD Aluminium Tube (includes 78 AL STD & 78 STEEL)
- Fabric:** 573gsm (19.36oz/yd²), 0.85mm Thick
- Weight Bar:** F72 HD External Weight Bar

LEGEND	DESCRIPTION	MAX SPRING ROTATIONS
	Outside Product Specifications	-
	Short RE01 Spring	25
	Standard RE01 Spring	38
	Heavy Duty RE01 Spring	31
	X-Heavy RE01 Spring	25
	Dual Heavy RE01 Springs	31 (Per Spring)

The above charts are indicative only and indicate the minimum number of pre-turns required. Due to variances in fabric weights, additional ballast weight and installations the optimum number of pre-turns will vary. Pre-turns can be adjusted during installation.

78mm Tube [F72 Weight Bar + 0.8kg/m Ballast]

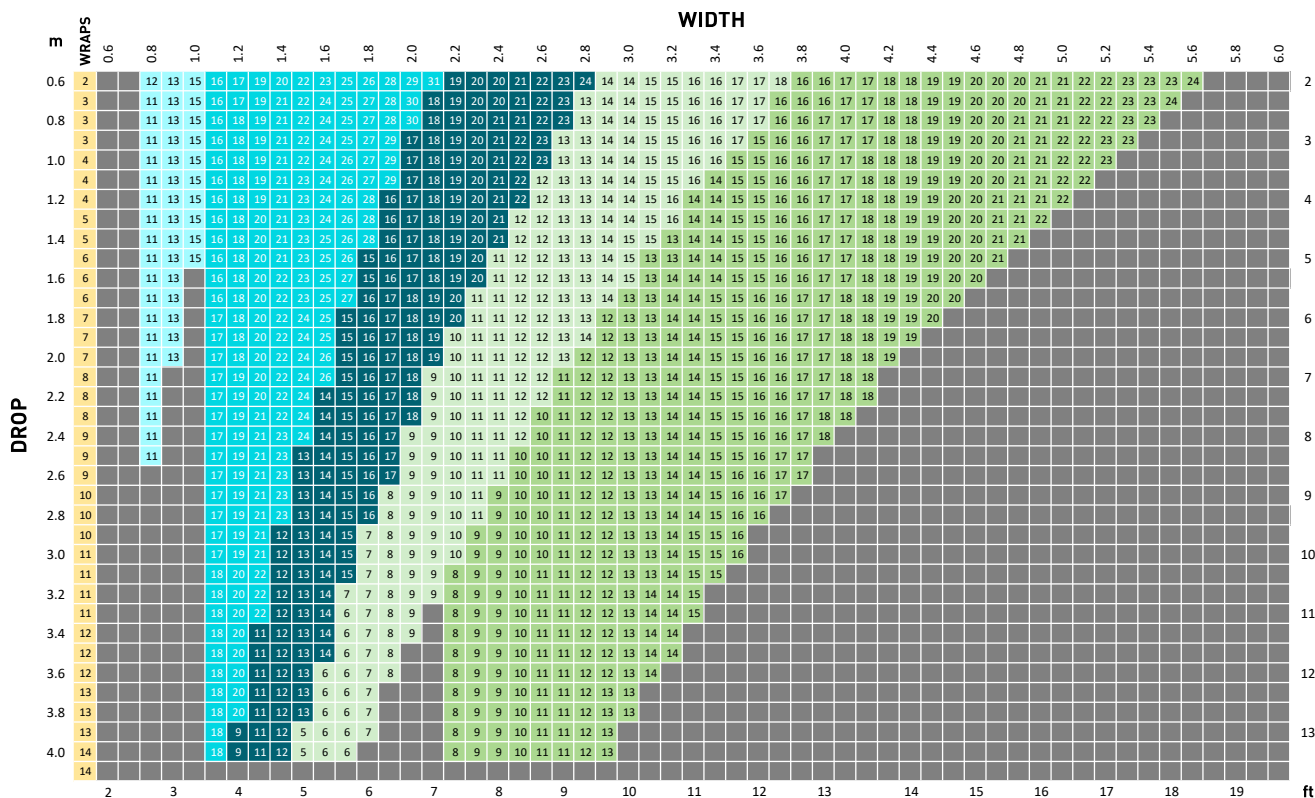

PARAMETERS

- Tube:** 78 HD Aluminium Tube (includes 78 AL STD & 78 STEEL)
- Fabric:** 573gsm (19.36oz/yd²), 0.85mm Thick
- Weight Bar:** F72 HD External Weight Bar + 0.8kg/m Ballast

LEGEND	DESCRIPTION	MAX SPRING ROTATIONS
	Outside Product Specifications	-
	Short RE01 Spring	25
	Standard RE01 Spring	38
	Heavy Duty RE01 Spring	31
	X-Heavy RE01 Spring	25
	Dual Heavy RE01 Springs	31 (Per Spring)

The above charts are indicative only and indicate the minimum number of pre-turns required. Due to variances in fabric weights, additional ballast weight and installations the optimum number of pre-turns will vary. Pre-turns can be adjusted during installation.

STEP 2 – LOCK SPRING AT SPRING END



Left Hand Locked

STEP 3 – ENGAGE SPANNER ONTO PRE-TENSION HEAD

Slide Down to Engage

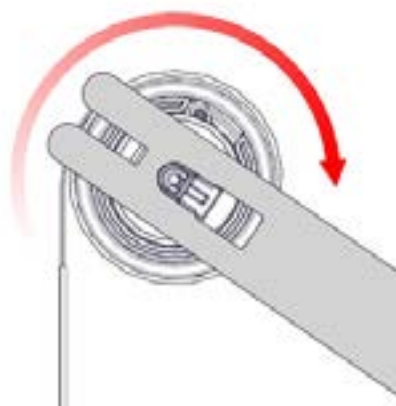
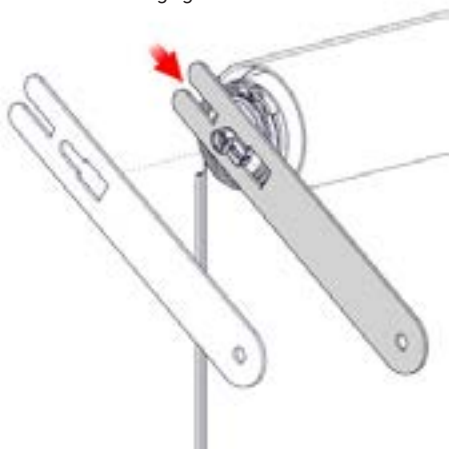

STEP 4 – PRE TURN SPRING DIRECTION INDICATED ON LABEL



LEFT HAND
Pre-Tension Clockwise



#Wraps + pre-turns must be less than max spring rotations.

Do not exceed max spring rotations.



Remove Spanner

Note: Gradually increase the number of pre-turns required. Only remove the pre-tension spanner when the spring tension is held by the internal mechanism, immediately after a 'click' is heard.

Pre-turn spring for number of times indicated in Spring tensioning charts. A click will be heard for each turn.

PART C – COVER ASSEMBLY

STEP 1 – DRILL CLEARANCE HOLES IN ‘END PLATE’ TO FACILITATE INSTALLATION FIXINGS

FACE FIX INSTALLATION OPTION



TOP FIX INSTALLATION OPTION

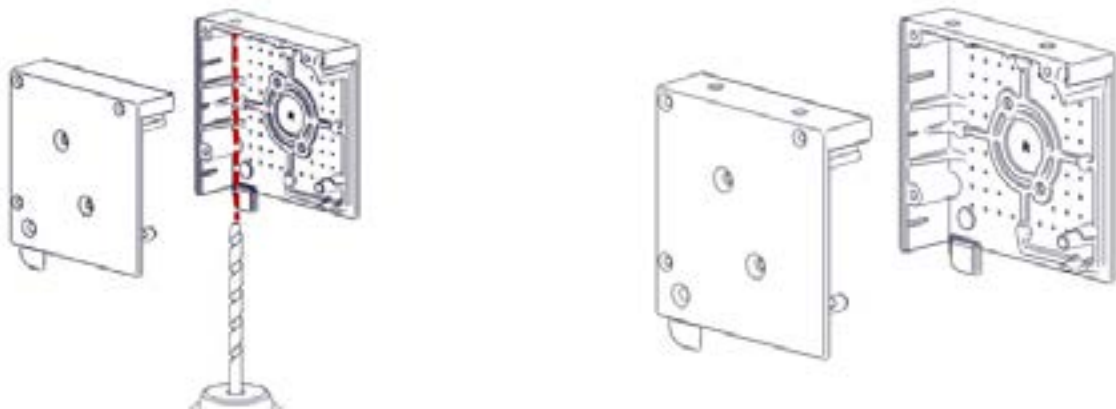

RECESS FIX INSTALLATION OPTION

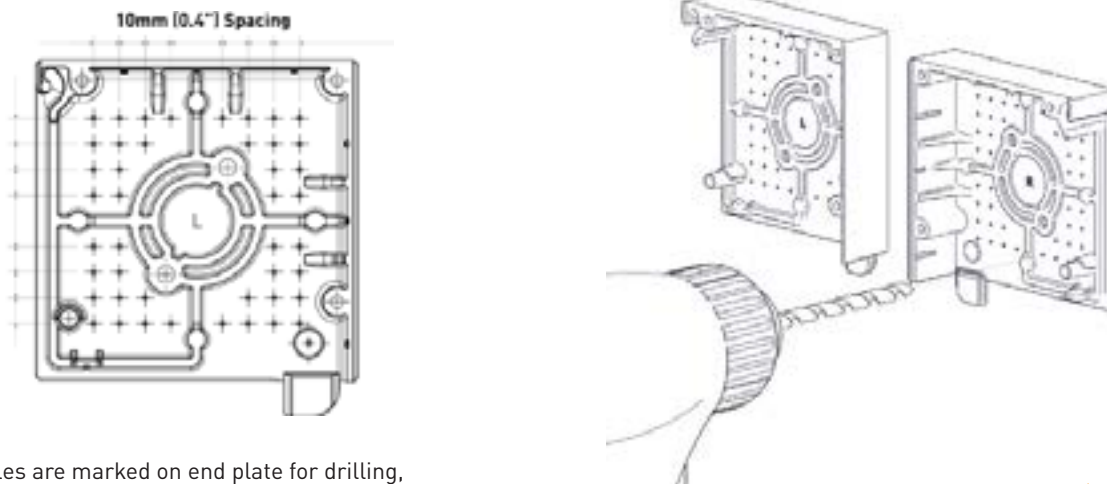

NOTE: Holes are marked on end plate for drilling,
For balanced installation drill holes at corresponding opposite sides of plate.

PART D – BOX INSTALLATION

STEP 1 – INSTALL BOX TO WALL/CEILING

FACE FIX

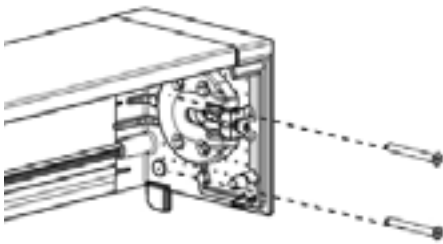

TOP FIX

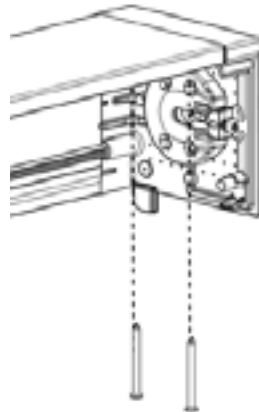

SIDE FIX

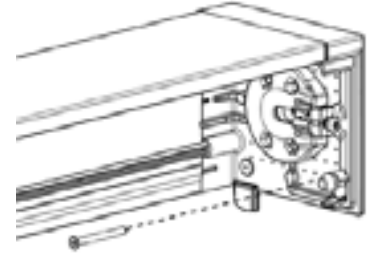

Note: Use appropriate fixings to suit application. Ensure Box is Aligned and Level.

PART E – COVER INSTALLATION

STEP 1 – INSTALL END PLATES TO WALL/CEILING USING APPROPRIATE FIXINGS TO SUIT APPLICATION

FACE FIX

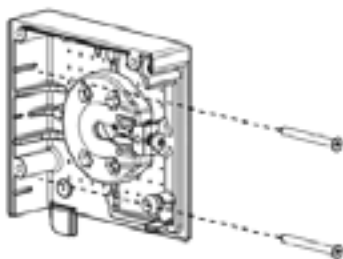

TOP FIX

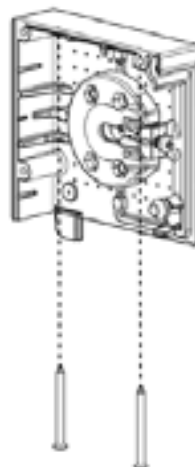

SIDE FIX

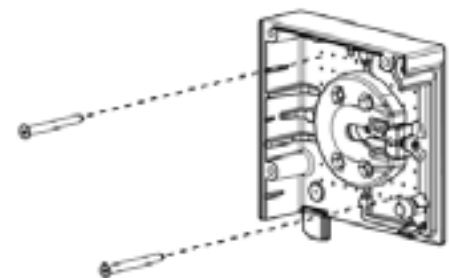

Note: 1. Use appropriate fixings to suit application. 2. Ensure End Plates are Aligned and Level. 3. Measure brackets end to end to confirm measurement is correct

PART F – OPEN BRACKET INSTALLATION

STEP 1 – INSTALL BRACKETS TO WALL/CEILING USING APPROPRIATE FIXINGS TO SUIT APPLICATION

FACE FIX

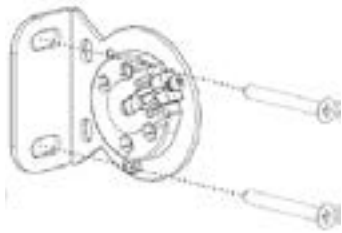

TOP FIX



SIDE FIX

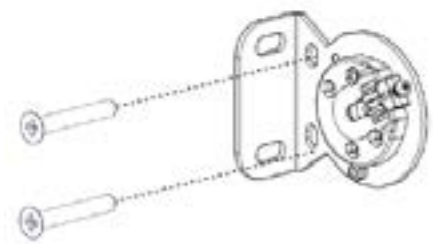

Note: 1. Use appropriate fixings to suit application. 2. Ensure brackets are Aligned and Level. 3. Measure brackets end to end to confirm measurement is correct

PART G – BLIND INSTALLATION

STEP 1 – INSERT BLIND INTO BOX

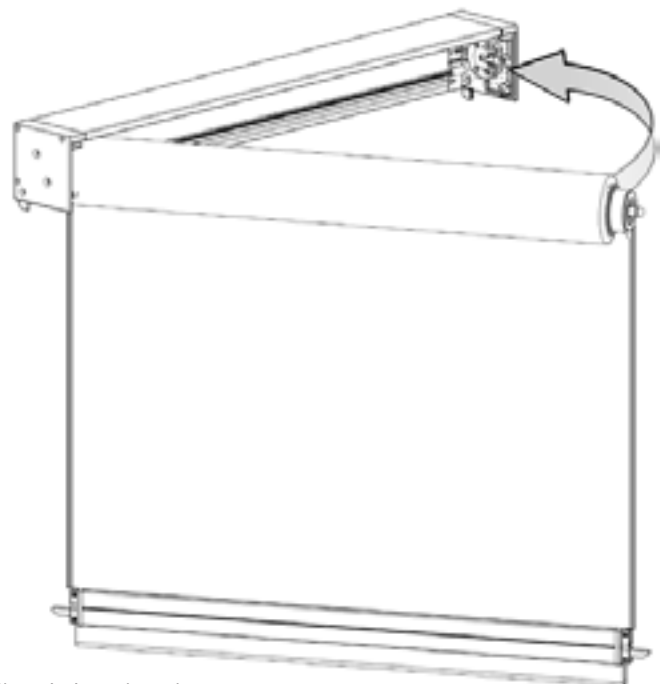
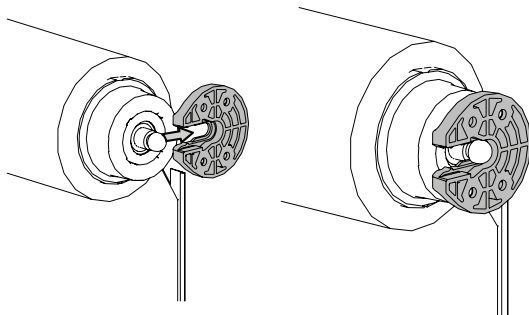

User effort will be required to push the booster head/Idler pin into the adapter, a noticeable “click” will indicate that the component is correctly located.

STEP 2 - INSERT RETAINER CLIP MKII ONTO IDLER ADAPTER

IDLER END

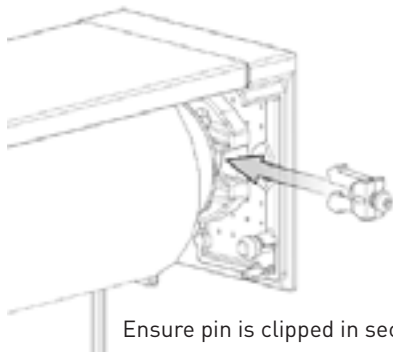

Ensure pin is clipped in securely

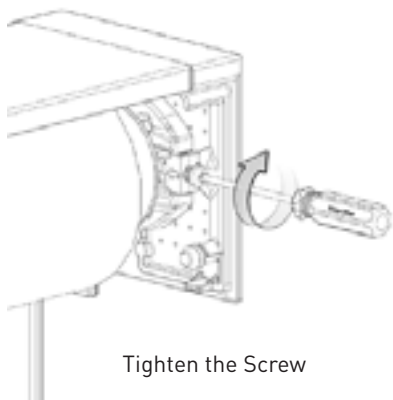

Tighten the Screw

CONTROL END

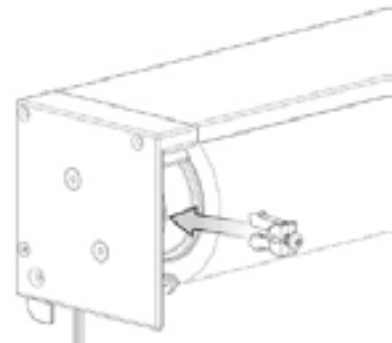

SPRING ONLY: Insert Retainer Clip MKII at spring end

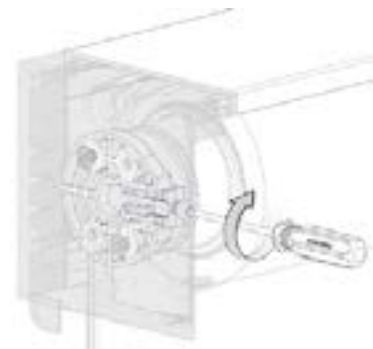

SPRING ONLY: Insert Retainer Clip MKII at spring end and tighten the screw to secure.

STEP 3 - UNLOCK PRE-TENSION HEAD AT SPRING END (FOR SPRING ONLY)

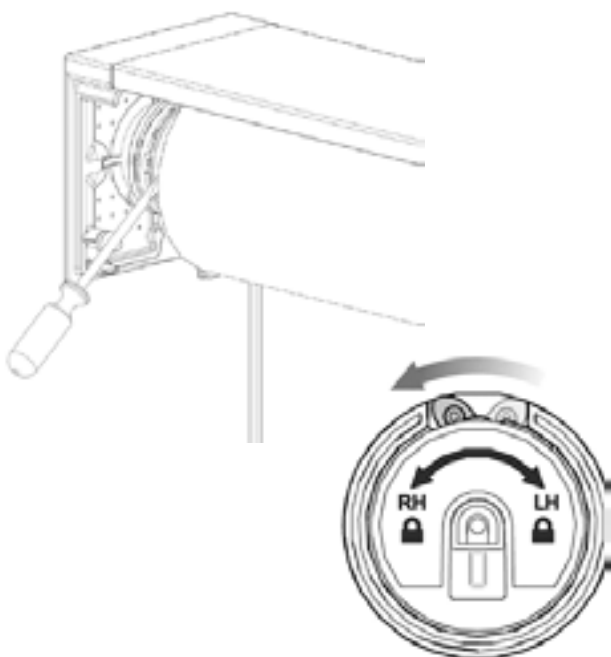

STEP 4 - FEED THROUGH MOTOR CABLE (FOR MOTOR ONLY)

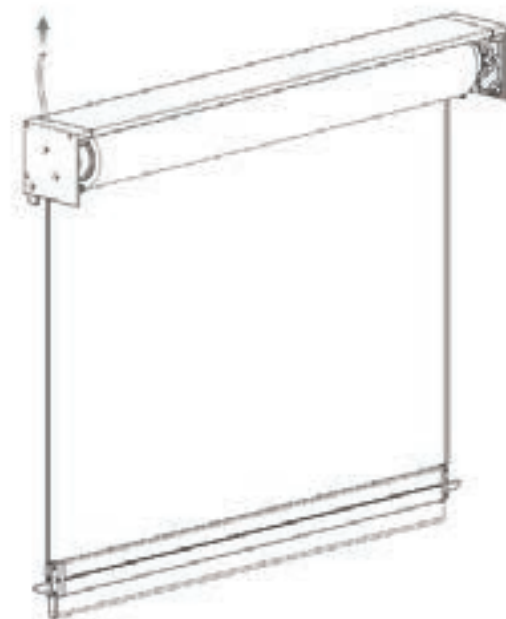

STEP 5 – RUN BLIND DOWN + CENTRE

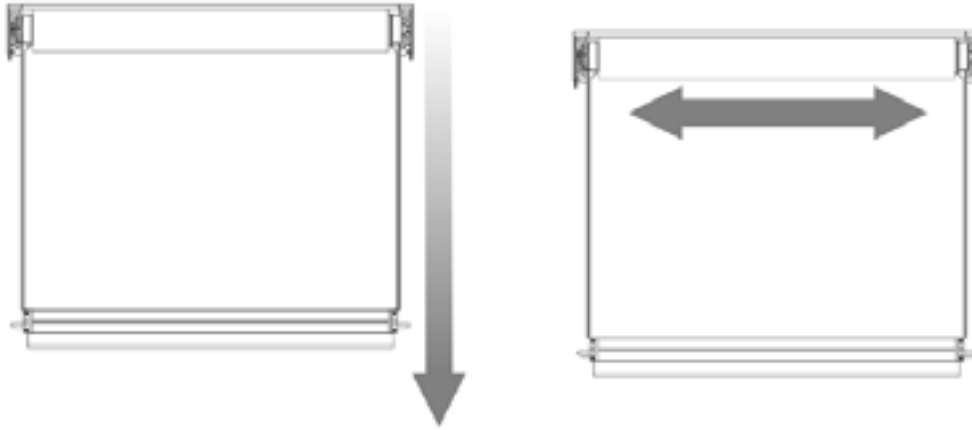

STEP 6 – TEST BLIND OPERATION



For spring operation, blind should creep up slowly when pulled down.

If blind does not creep up, add more pre-turns. For motor operation, ensure wiring is correct and motor is operating correctly.

For gear operation, ensure operation is smooth.

PART H – ADJUSTING PRE-TURNS (SPRING OPERATED BLINDS ONLY)

STEP 1 – TO ADJUST PRE-TURNS, LOCK PRE-TENSION HEAD

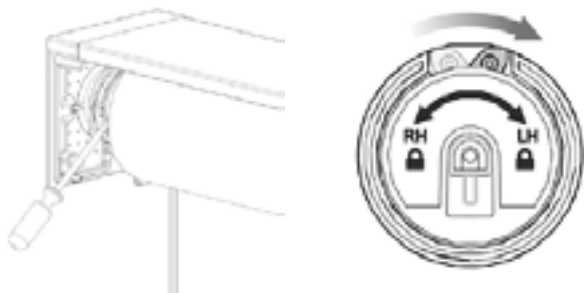

Note: Ensure spring is locked by lifting weight bar until fabric bunches up.

STEP 2 – DISENGAGE THE SPRING HEAD FROM ADAPTER

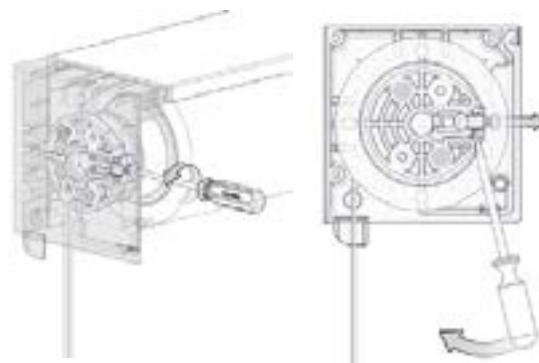

Loosen the screw then lever the Retainer Clip MKII outwards.

STEP 3 – ADD ADDITIONAL PRE-TURNS REQUIRED

Note: Gradually increase the number of pre-turns required. Only remove the pre-tension spanner when the spring tension is held by the internal mechanism, immediately after a 'click' is heard.



#Wraps + pre-turns must be less than max spring rotations.
Do not exceed max spring rotations.



STEP 4 – UNLOCK PRE-TENSION HEAD

Note: When the weight bar is pulled down, the tension in the spring will be released.



STEP 5 – RE-INSTALL AND TEST BLIND



If too many pre-turns are added, the blind will automatically raise.

Note: Re-install and secure Retainer Clip when complete.

PART I – SIDE GUIDE INSTALLATION

STEP 1 – MARK OUT SIDE GUIDE POSITION AND ALIGN RAIL (FOR OPEN BRACKET ONLY)

SIDE FIX

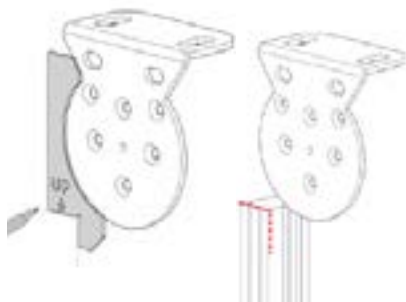

Note: Use Open Bracket Template (RE01-3012-033000) to assist

FACE FIX

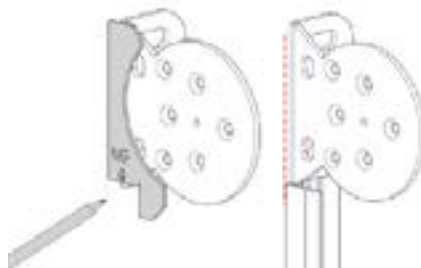

Use thickness of Open Bracket Template to mark position of L-Fixing Rail

FACE FIX U-MOUNTING RAIL



Rail to sit flush to bracket

STEP 2 – MOUNT L-FIXING RAIL TO WALL ON BOTH SIDES (FOR FACE FIX ONLY)

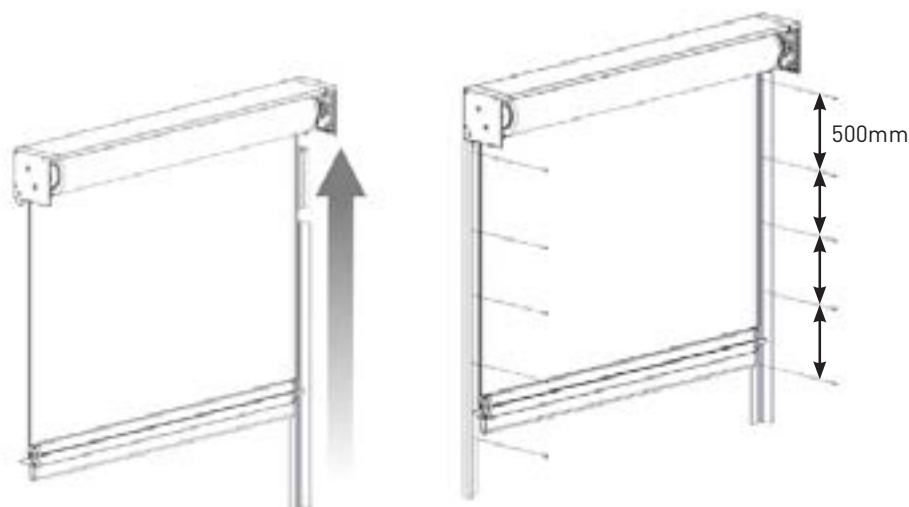

Use an off cut of the U mounting rail to install the L-fixing rail at the correct distance from the end plate.

STEP 3 – INSERT U-MOUNTING RAIL/FACE FIX U-MOUNTING RAIL



Locate ear of end plate with U-mounting rail



L-Fixing Rail + U-Mounting Rail + ear of end plate



Face Fix U-Mounting Rail + ear of end plate

STEP 4 – SECURE U-MOUNTING RAIL TO SIDE FIX SURFACE OR L-FIXING RAIL

FACE FIX: L – FIXING RAIL

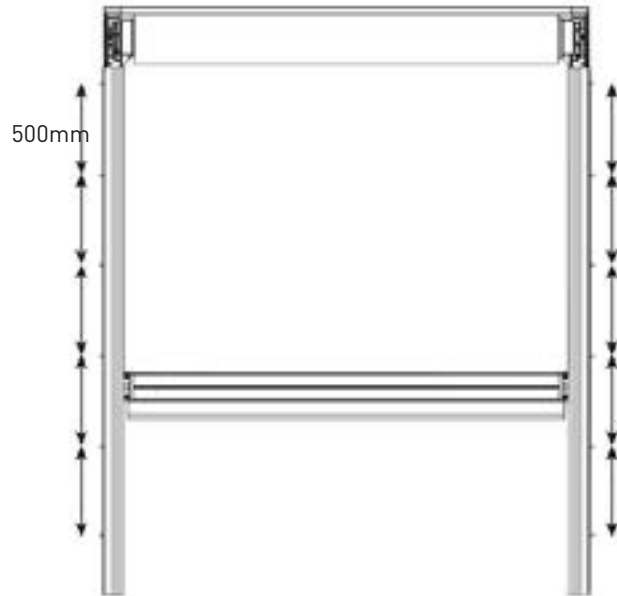

FACE FIX: U – MOUNTING RAIL

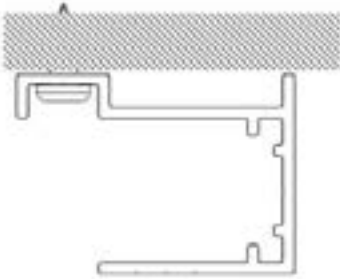

SIDE FIX

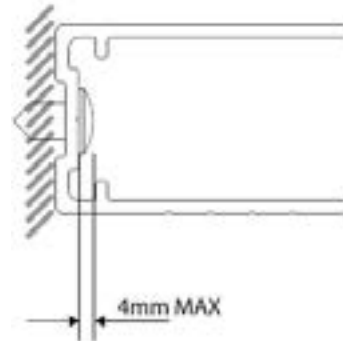

STEP 5 – REMOVE THE STOPS FROM THE FUNNEL IN THE INNER RAILS

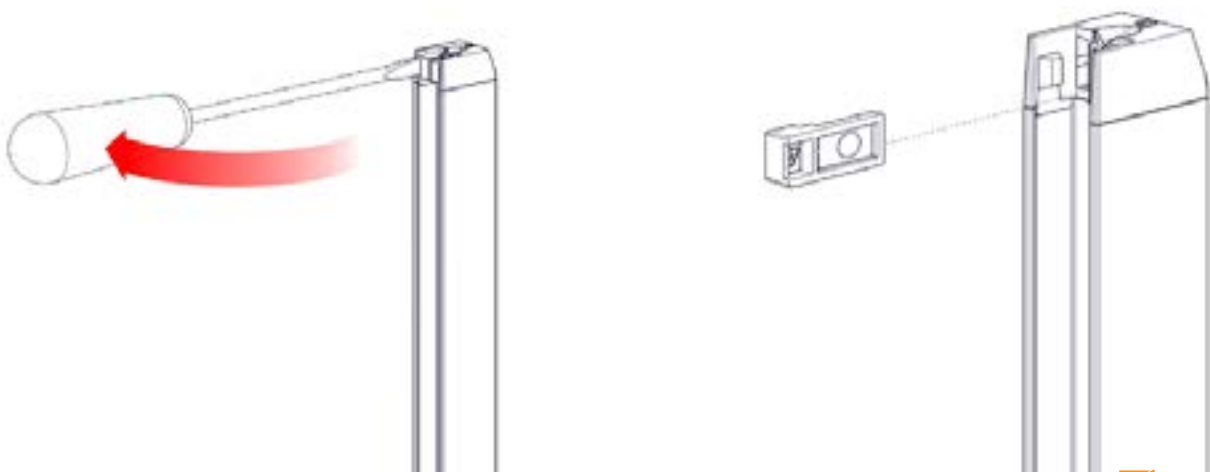

STEP 6 – SWING INNER RAIL INTO THE U MOUNTING RAIL ON AN ANGLE ON BOTH SIDES

- Ensure weight bar is 50-100mm from box
- Feed zip into funnel

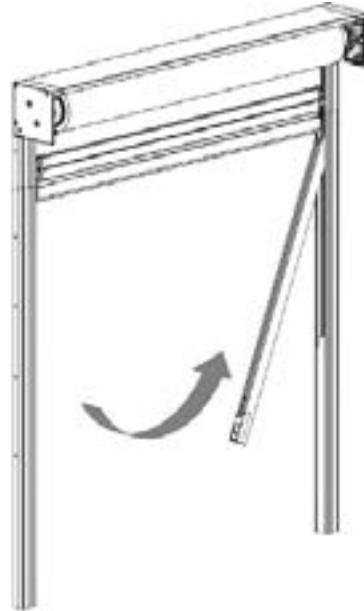

STEP 7 – PUT STOPS BACK INTO FUNNEL

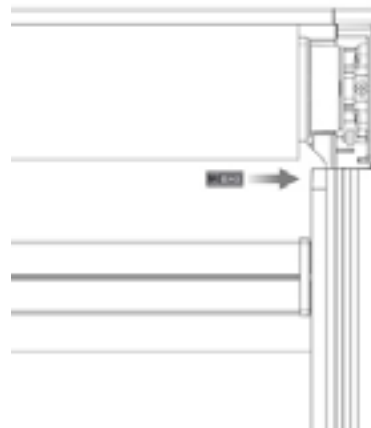
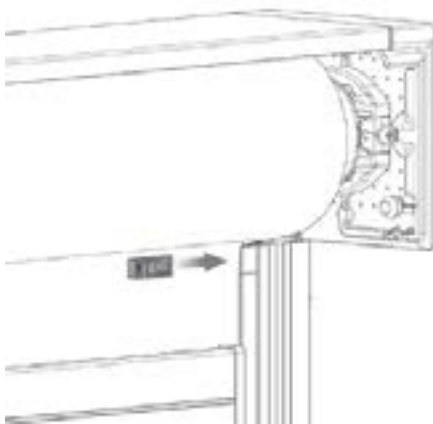

If there is inadequate access to the back of the blind to attach stops, add only one to the front of the blind on both ends

STEP 8 – OPERATE BLIND MULTIPLE TIMES TO ALLOW INNER RAIL TO MOVE INTO NATURAL POSITION

The inner rail should sit parallel with the zip to avoid strain or jamming of blind during operation.

Ensure the zip is running inside the inner rail on both sides.

When using the Ultra-Lock, the Latch Housings must be level with each other to ensure the Ultra-Lock Pins lock simultaneously.

Adjust the position of the Inner Rails as required.



STEP 9 – SECURE THE INNER RAILS

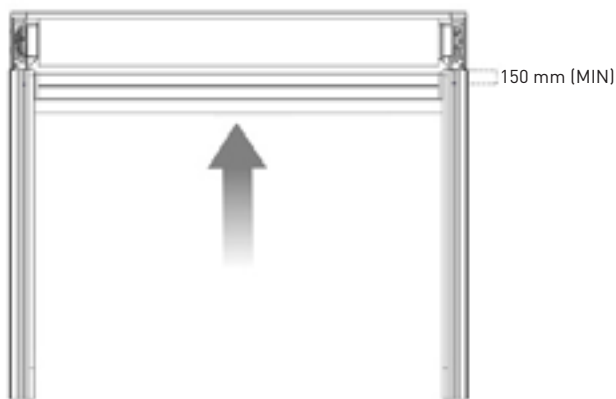

Run the blind up and secure the inner rails at the top of the blind on both sides

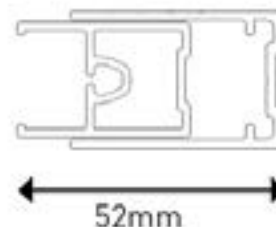

Screw/ Rivet inner rail at central position.
Pre-drill 4mm holes for rivets.
Rivet: Dome head, body diameter 4.0mm
Grip range: 4.8 – 6.4mm stainless steel
Tek screws can also be used to secure Inner rail into place.



Run the blind down and secure the inner rail at the bottom on both sides

Ensure inner rail is level before fixing

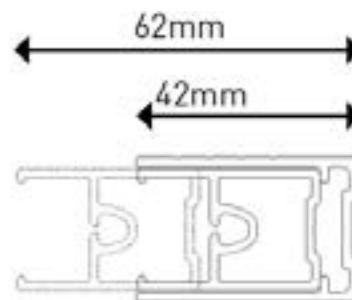

The overall dimension of the U mounting rail and Inner rail must be between 42mm - 62mm.

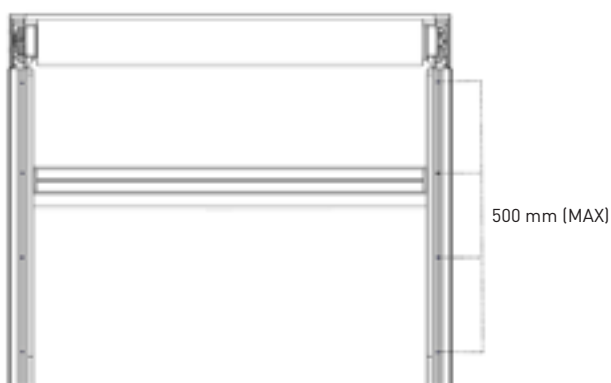

Move the blind to the next fixing position and secure the inner rails along the length of the blind on both sides. Do not force the inner rail; it should be in its natural position.

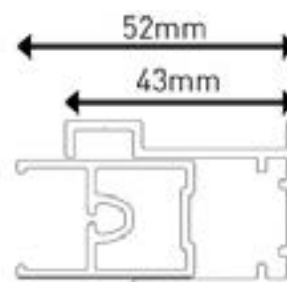

The overall dimension when using Face Fix U Mounting Rail and inner rail is 43 – 52mm.

STEP 10 – TEST OPERATION AND APPEARANCE OF BLIND

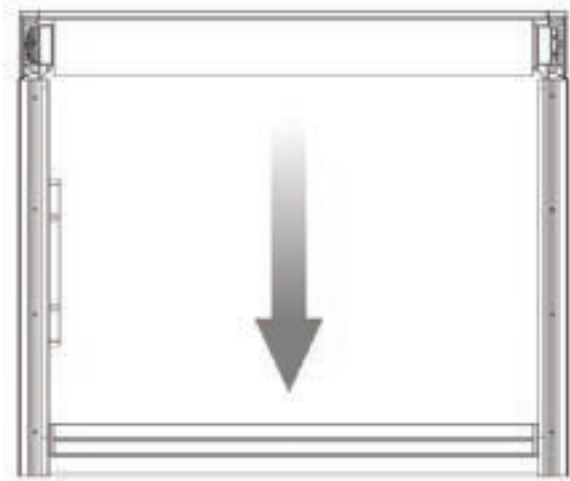

Check inner rails are level and parallel

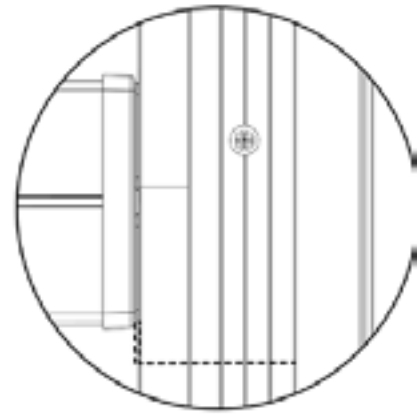

IMPORTANT:

The distance between the weight bar end cap and the edge of the inner rail should always be approximately 3mm (0.12")

STEP 11 – (NOT FOR ULTRA-LOCK) – SET MOTOR LIMITS (MOTOR CONTROL ONLY)



TOP LIMIT: Set top limit as required (should be as close to the box as possible)



BOTTOM LIMIT: Set to the lowest point possible. Ensure seal is compressed as much as possible.

PART J – ULTRA-LOCK MOTOR SETTINGS

STEP 1 – INITIAL SETUP

PAIR MOTOR WITH CONTROLLER

Select channel on controller.



Hold **P1** button on motor head.

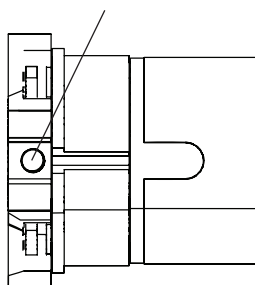

Hold **STOP** on controller.



Consult user manual for your controller for information on selecting channel.

Motor Response



Motor Response



CHECK FOR MOTOR DIRECTION

To check travel direction of shade, press **UP** or **DOWN** on controller.



To reverse shade direction, hold both **UP** and **DOWN**. Until the motor responds.



Quick Press = Step
Long Press = Continuous Travel

Motor Response



Damage to shade may occur when operating motor prior to setting limits. Attention should be given.



STEP 2 – SET UPPER LIMIT

Setting limits with this method is only possible during initial set up. Refer to Part J for adjusting motor limits.

Move shade to the desired highest position by pressing the **UP** button on controller.

To save upper limit, hold **UP** and **STOP**.



IMPORTANT

Cycle shade up and down prior to setting limits to settle fabric.

Motor Response



Initial set-up is not complete.

IMPORTANT

After setting limits, motor will automatically exit from initial set-up mode.

STEP 3 – SET LOWER LIMIT (LOCK POSITION)

Setting limits with this method is only possible during initial set up. Refer to Part J for adjusting motor limits.

IMPORTANT

The motor lower limit must be set correctly between the locking & unlocking position. Jog the motor down to find the lock position (Jog until you hear BOTH pins click), then set the lower limit.

Move shade to lock position by pressing the **DOWN** button on controller.

To save lower limit, hold **DOWN** and **STOP**.



Motor Response



STEP 4 – ACTIVATE FABRIC TENSION MODE

Once the bottom limit is set, FT Mode will need to be activated to operate the Ultra-Lock.

Press **P2** on controller.

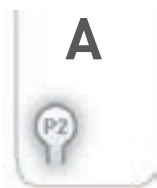

Press **UP** on controller.



Press **UP** on controller.



FT MODE:

Motor Response



NO FT MODE:

Motor Response



IMPORTANT

Initial setup is complete. You may now operate the shade normally.

PART K – ULTRA-LOCK OPERATION (MOTOR OPERATION)

STEP 1 – LOCKING

Press **DOWN** on the controller. The motor will lower the weight bar to the set bottom limit, then automatically tension the fabric.



Note: Make sure that the FT mode is turned ON whilst locking and unlocking the blind.

STEP 2 – UNLOCKING

Press **UP** on the controller. The motor will lower the weight bar past the bottom limit to unlock, then raise the weight bar continuing to the upper limit.



Note: Make sure that the FT mode is turned ON whilst locking and unlocking the blind. Refer to step 4 for instructions.

PART L – ADJUSTING MOTOR LIMITS

STEP 1 – ADJUST UPPER LIMIT

Hold **UP** and **STOP** on controller.



Move shade to the desired highest position by pressing the **UP** button.



To save upper limit, hold **UP** and **STOP**.



Motor Response



Motor Response



STEP 2 – ADJUST LOWER LIMIT (LOCK POSITION)

IMPORTANT

The motor lower limit must be set correctly between the locking & unlocking position. Jog the motor down to find the lock position (Jog until you hear BOTH pins click) then set the lower limit.

Hold **DOWN** and **STOP** on controller.



Move shade to the desired lowest position by pressing the **DOWN** button.



To save lower limit, hold **DOWN** and **STOP**.



Motor Response



Motor Response



PART M - ULTRA-LOCK OPERATION (MANUAL OPERATION)

SPRING CONTROL

LOCKING

STEP 1 - LOWER THE WEIGHT BAR TOWARDS THE LOCK UNTIL YOU HEAR IT CLICK ONCE

If 2 'clicks' are heard the weight bar has been lowered into the 'unlock' position. Raise the weight bar and try again to lock.

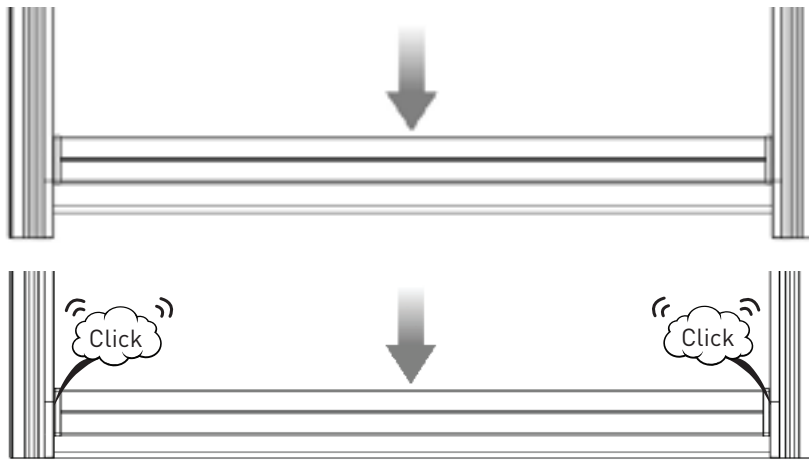

STEP 2 - RELEASE THE WEIGHT BAR



UNLOCKING

STEP 1 - LOWER THE WEIGHT BAR ALL THE WAY DOWN PAST THE LOCKING POINT



STEP 2 - RAISE THE WEIGHT BAR



CRANK CONTROL

LOCKING

STEP 1 – ROTATE THE CRANK TO LOWER THE WEIGHT BAR TOWARDS THE LOCK UNTIL YOU HEAR IT CLICK ONCE

If 2 'clicks' are heard the weight bar has been lowered into the 'unlock' position. Raise the weight bar and try again to lock.

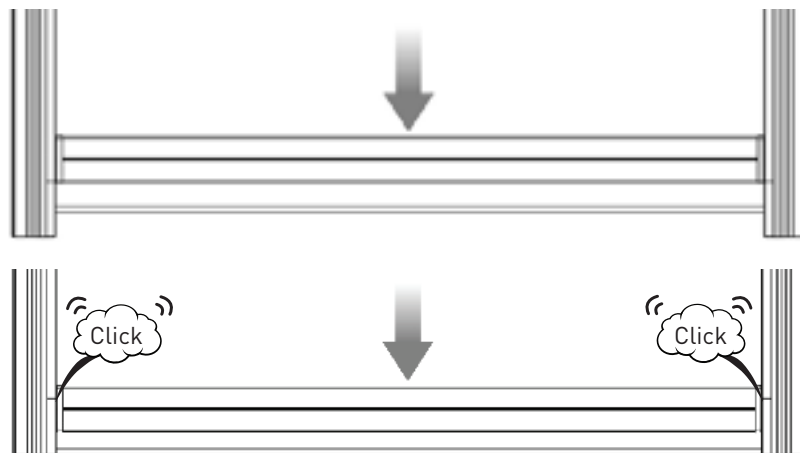

STEP 2 – ROTATE THE CRANK IN THE OPPOSITE DIRECTION TO TENSION THE WEIGHT BAR



UNLOCKING

STEP 1 - ROTATE THE CRANK TO LOWER THE WEIGHT BAR ALL THE WAY DOWN PAST THE LOCKING POINT



STEP 2 - ROTATE THE CRANK IN THE OPPOSITE DIRECTION TO RELEASE THE WEIGHT BAR

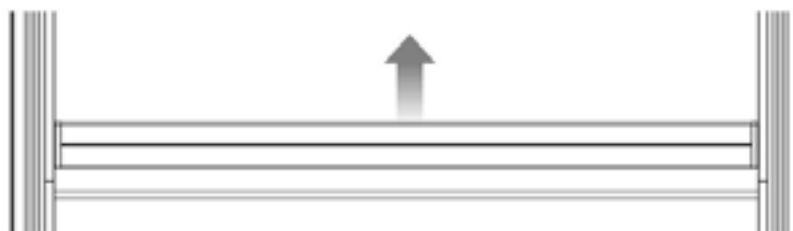

PART N – WEIGHT BAR SB07 LATCH INSTALLATION

STEP 1 – BRING WEIGHT BAR TO DESIRED LOCKED POSITION

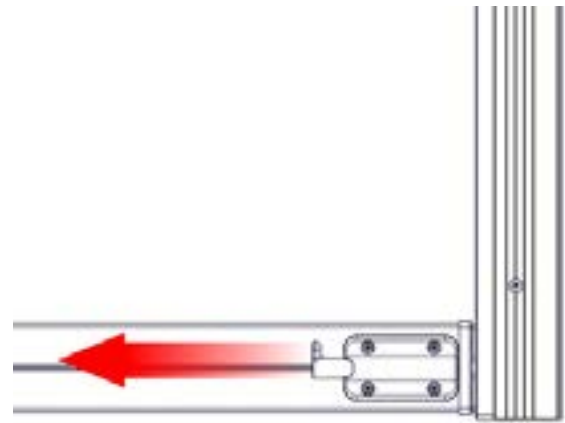

Ensure shaft of the lock is retracted

STEP 2 – SECURE LATCH TO U-MOUNTING RAIL

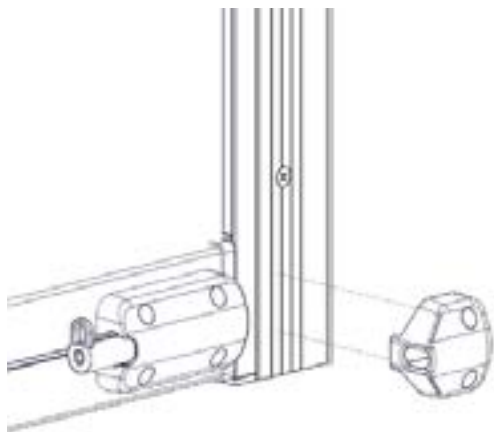

Align lip of latch to U-Mounting Rail



STEP 3 – ADD ADDITIONAL LATCHES (IF REQUIRED)

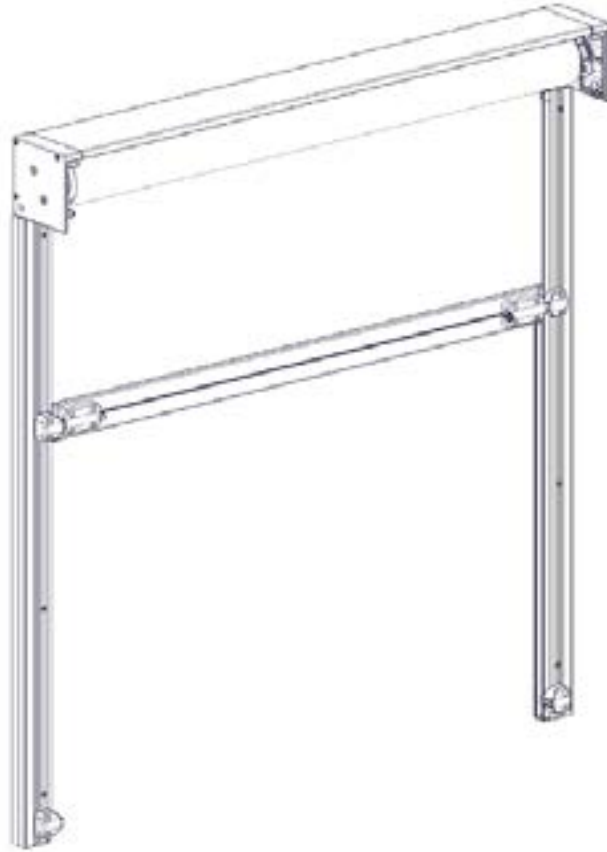

PART 0 – INSERT BOX / COVER

STEP 1 – SWING BOX COVER INTO BOX TOP AND CLIP INTO PLACE



STEP 2 – SECURE COVER AT BOTH ENDS

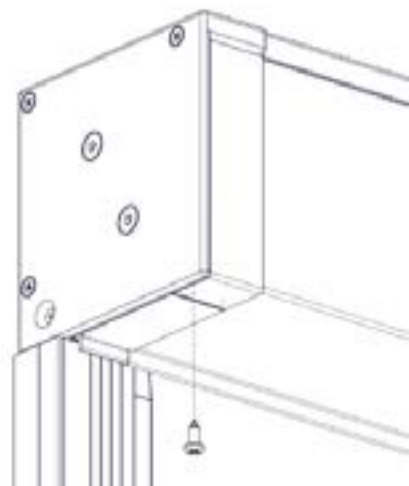

PART A – MULTIPLE BLINDS INSTALLED SIDE BY SIDE ON A FACE

STEP 1 – MARK OUT CORRECT POSITION WHERE COMPLETE FACE FIX BLINDS ARE TO BE INSTALLED



It is important to install the blinds so that they match the initial measure.

STEP 2 – INSTALL BOX OR BRACKETS FOR BLIND 2



BLIND 2

Refer to Section B, Parts C

STEP 3 – INSTALL L FIXING RAILS FOR BLIND 2



BLIND 2

Refer to Section B, Part G

STEP 4 – ENSURE L FIXING RAILS ARE AT THE CORRECT WIDTH FOR BLIND 2

Adjust L fixing rails if required. If blind 02 occupies installation space allocated to blind 1 or blind 3, operational or installation problems will occur with these blinds.



STEP 5 – INSTALL BOX OR BRACKETS FOR BLIND 1 & 3



Refer to Section B, Parts C

STEP 6 – INSTALL L FIXING RAILS FOR BLIND 1 & 3



Refer to Section B, Parts G

STEP 7 – ENSURE L FIXING RAILS ARE AT THE CORRECT WIDTH FOR BLINDS 1 & 3



Adjust L fixing rails and box or bracket installation if required.

STEP 8 – ATTACH U MOUNTING RAILS ON BLINDS 1, 2 & 3

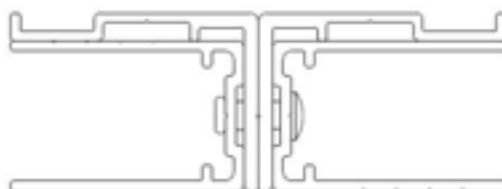

Rivet U Mounting rails to L fixing rails to all 3 blinds

STEP 9 – COMPLETE BLIND INSTALLATION FOR BLIND 2

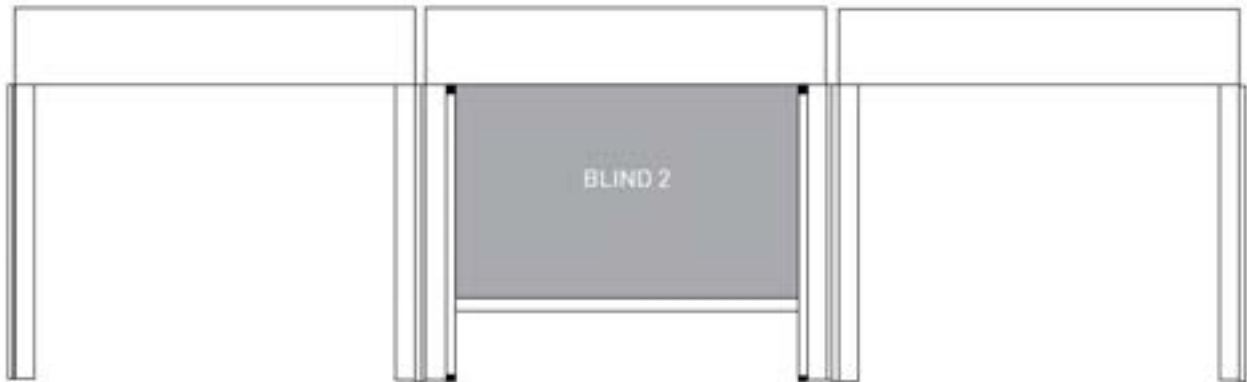

Ensure blind is correct width as specified in initial measure.

STEP 10 – COMPLETE BLIND INSTALLATION FOR BLIND 1 & 3



Ensure blind is correct width as specified in initial measure.

FOR MORE THAN 3 BLINDS

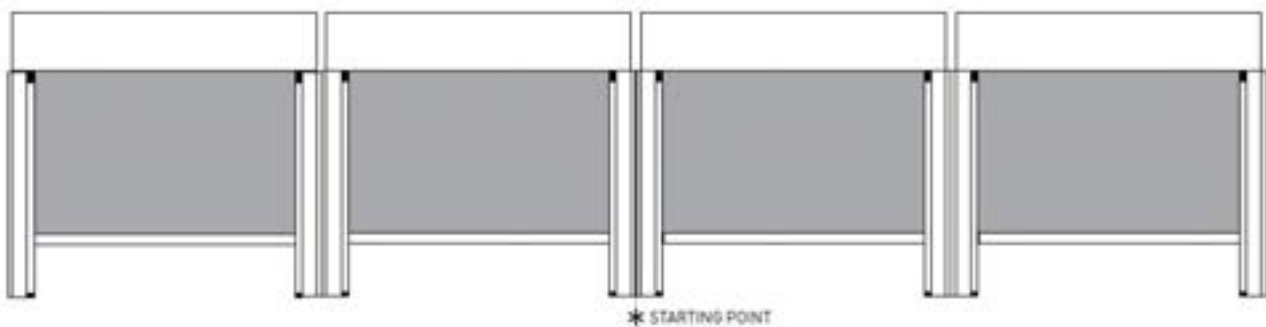

Apply same principles outlined in previous steps when there are several blinds side by side

NO.	PROBLEM	CAUSE	SOLUTION
1	Prominent smile across fabric	Not enough tension in side guides	Cut new fabric skin and weld zip onto fabric ensuring temperature is not too hot. Refer to Assembly manual for welding tips.
		Fabric is not installed straight	Ensure fabric is assembled straight onto tube and weight bar.
2	Ripples along sides of fabric	Blind rolled up for extended period of time	This occurrence is inherent to roller systems and is more prevalent in some fabrics. Leave blind down for 1-4 hours – most ripples should disappear.
		Fabric not central to system	Remove rivets around the ripple area and reposition inner rail and secure
		Too much tension in inner rails	Check fabric is centred with system. If the fabric is not centred with the system, centre the fabric. The Side Rails may need to be removed to correct. If fabric cannot be centred, check scallop in fabric is large enough for installation (refer to Assembly manual for scallop sizes). If the fabric at the scallop is flush with the edge of the tube and the fabric cannot move sideways any further, increase size of scallop in fabric.
		Fabric is too wide for installation	Check actual installation width dimension matches the measured blind width. If the installation width does not match the measured blind width: <ul style="list-style-type: none"> • Correct installation width to match measured blind width or • Correct fabric width to correct size (based on actual installation width) Note: Tube and weight bar may also require correcting. If the installation width matches the measured blind width: Check overall fabric width from external zip edge to external zip edge and ensure it is W-66mm (W being completed blind width). If required, correct fabric width.
		Not enough weight in weight bar.	Refer to product specs. Add ballast. Note: for spring operated blinds, the number of pre-turns will most likely need to be increased.
		Spring operated blinds	It is more common for there to be some ripples in spring operated blinds. To reduce the number of ripples evident, pull the blind down softly and lock into position.
		Not enough pre-turns in spring	Increase number of pre-turns on spring.
		Installation is not square	Check overall width of U-mounting rail and inner rail is within 42-62mm. Check inner rails are level & parallel. If either of the above checks are not in accordance with specifications, the installation space requires additional packing. The side rails or entire systems may need to be removed to correct.

NO.	PROBLEM	CAUSE	SOLUTION
		Fabric permanently damaged due to inadequate handling during assembly, transportation, installation or use	Replace the fabric and ensure it is handled with care.
		Fabric is not installed straight	Ensure fabric is assembled straight onto tube and weight bar.
3	Small ripples close to weld	Welding temperature is too high on zip	Cut new fabric skin and weld zip onto fabric ensuring temperature is not too hot. Refer Assembly manual for welding tips.
4	Blind gets jammed half way down	Weight bar end cap hits Inner Rail	<p>Check there is always approximately 3mm (0.12") gap between Weight Bar End Cap and Inner Rail.</p> <p>If there is insufficient clearance, check:</p> <ul style="list-style-type: none"> • Actual installation width dimension matches the measured blind width • The weight bar length is cut in accordance with the deductions outlined by Acmeda <p>If the installation width does not match the measured blind width:</p> <ul style="list-style-type: none"> • Correct installation width to match measured blind width or • Trim weight bar length to correct size (based on actual installation width) <p>Note: Tube and fabric may also require correcting</p>
		Fabric is not installed straight	Ensure fabric is assembled straight onto tube and weight bar.
5	Spring operated blind is heavy to push up	Not enough pre-turns	Increase number of pre-turns on spring.
6	Spring operated blind is stuck and will not move	Spring pre-tension Idler has not been un-locked.	Ensure pre-tension Idler is unlocked on both ends of system.
7	Motorised blind jolts during operation	Motor rotates blind continuously whilst a wind gust causes additional friction in Inner Rail and stops blind momentarily. When force of wind is reduced, the additional friction is removed and blind drops.	This occurrence is inherent to the motorised system and no damage will be caused as a result. If undesired, avoid operating blind in windy conditions.
		Not enough weight in weight bar	Add ballast to weight bar.
8	Cannot install inner rail into blind to feed zip	Weight bar length is too long	<p>Check actual installation width dimension matches the measured blind width.</p> <p>If the installation width does not match the measured blind width:</p> <ul style="list-style-type: none"> • Correct installation width to match measured blind width or • Trim weight bar length to correct size (based on actual installation width) <p>Note: Tube and fabric may also require correcting</p>

NO.	PROBLEM	CAUSE	SOLUTION
		Inner rail length is too long	<p>Check actual installation drop dimension matches the measured blind drop. If the installation drop does not match the measured blind drop:</p> <ul style="list-style-type: none"> • Correct installation drop to match measured blind drop or • Trim inner rail length to correct size (based on actual installation width) <p>Note: U-mounting rail and L-fixing channel may also require correcting</p>
9	SB07 Weight Bar lock doesn't locate into latch	Latch has not been secured in correct position	Re-install latch so shaft locates into latch.
10	Uneven weight bar	Box is not level, thus weight bar appears uneven	Ensure box is level.
		Inconsistent friction along inner rails	Check inner rails are level & parallel. If the inner rails are not level and parallel remove rivets from U-mounting channel, reposition inner rail to reduce tension and re-secure inner rail.
		Motorised blind jolts during operation	See Point 7
		Zip overturns on itself	This occurrence is inherent to Zipscreen and there isn't currently a solution.
		Fabric is not installed straight	Ensure fabric is assembled straight onto tube and weight bar.
11	Impact Detection function of Automate FT motor is not active.	The Automate FT motor Impact Detection function isn't active in the first 20cm from the upper limit and in the last 20cm from the lower limit.	Put the blind up or down, increasing the distance from the limits and verify if the motor retracts the blind when an obstacle is detected.
		Impact Detection function has been deactivated during motor installation.	Press P2, Down & Down on the remote and check the functionality of Impact Detection again.

OMBRA EXTERNAL AWNINGS



inspired spaces

- > 1800 007 321
- > apollopatios.com.au

